

# 17"X30"X24" HANDHOLE SERIE

## INTRODUCTION

The handhole/manhole is designed for underground distribution systems, especially for fiber optical and electricity industries. Manufactured with innovated composite material, making Aether handhole/manhole an ideal solution of strong, light, flexible, time & cost saving comparing to concrete manholes.

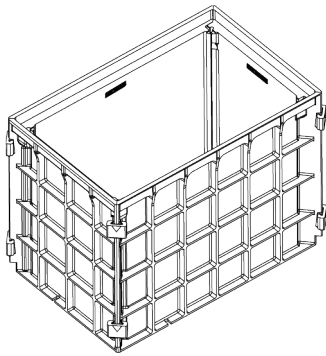

## ADVANTAGES

- Modular design with knock-down delivery and on-site set up
- Strong but light composite material construction
- Cost saving due to light weight, modular design
- Flexible to drill on wanted size for duct access; Duct entry provided
- Durability and resistance of entire construction up to SCTE-77 Tier

## Specifications

AE1730-4	Manhole	Cover
<b>Load Bearing</b>	SCTE-77 Tier22	SCTE-77 Tier22
<b>Internal size</b>	17"x30" inch	21"x32" inch
<b>External size</b>	22"x34" inch	
<b>Height</b>	24" inch	2" inch
<b>Weight</b>	65 lbs	48 lbs
<b>Fastening</b>	FastClip	S.S Screw

 [info@aetherfiber.com](mailto:info@aetherfiber.com) | [aetherfibersolutions.com](http://aetherfibersolutions.com)  +1 (844) 238-4371

