

24"X36"X24" HANDHOLE

INTRODUCTION

Aether handhole/manhole is designed for underground distribution systems, especially for fiber optical and electricity industries. Manufactured with innovated composite material, making Aether handhole/manhole an ideal solution of strong, light, flexible, time & cost saving comparing to concrete manholes.

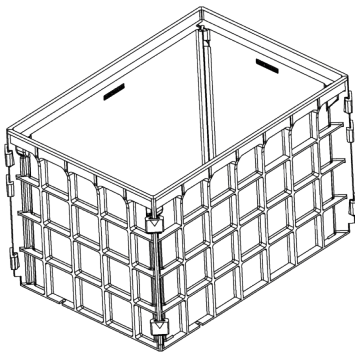
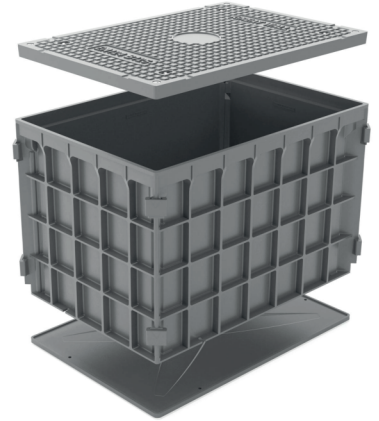

ADVANTAGES

- Modular design with knock-down delivery and on-site set up
- Strong but light composite material construction
- Cost saving due to light weight, modular design
- Flexible to drill on wanted size for duct access; Duct entry provided
- Durability and resistance of entire construction up to SCTE-77 Tier

Specifications

AE2436-4	Manhole	Cover
Load Bearing	SCTE-77 Tier22	SCTE-77 Tier22
Internal size	24"x36" inch	26"x39" inch
External size	26"x39" inch	
Height	24" inch	1.5" inch
Weight	78 lbs	77 lbs
Fastening	FastClip	S.S Screw

 info@aetherfiber.com | aetherfibersolutions.com  +1 (844) 238-4371

