

# POLYMER CONCRETE HANDHOLE

DATASHEETS **SPLIT LIDS**

## 36"X60"X48"

**TIER 22:** Driveway, parking lot, and off-roadway applications subject to occasional non deliberate heavy vehicular traffic.

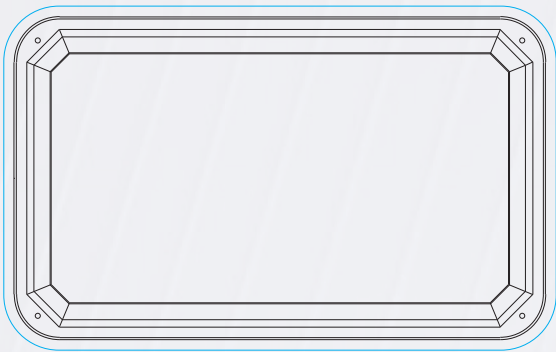

**BOX TOP VIEW**

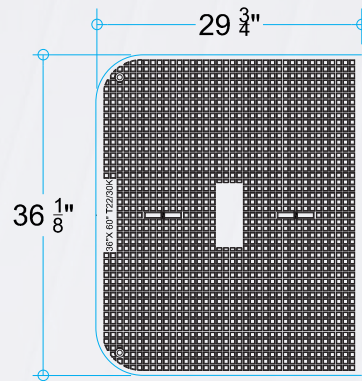

**COVER TOP VIEW**

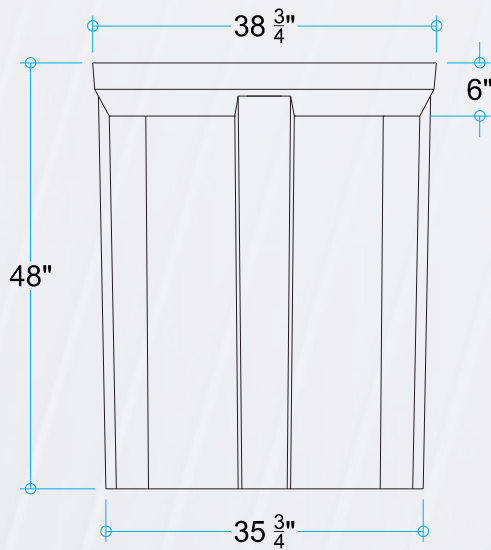

**SIDE VIEW**

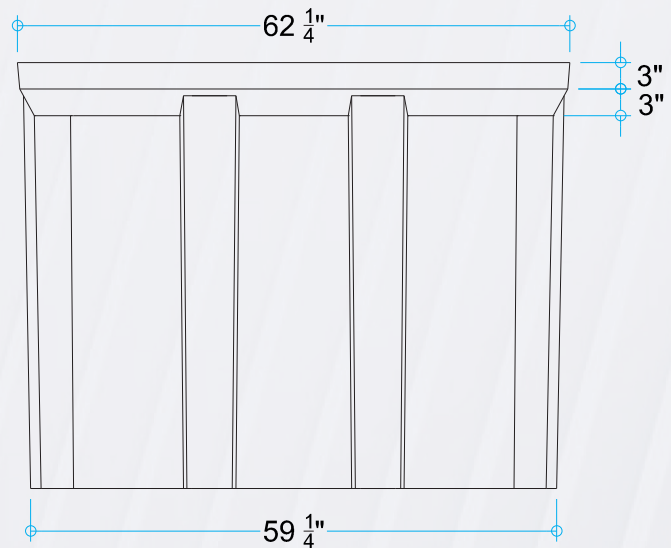

**FRONT VIEW**

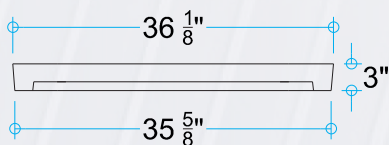

**COVER SIDE VIEW**

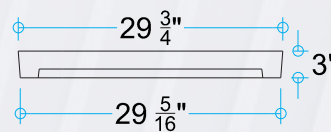

**COVER FRONT VIEW**



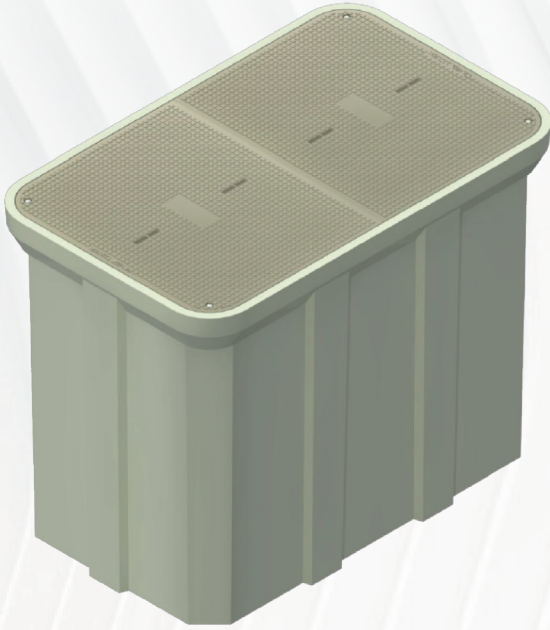

## • FEATURES

- Polymer Concrete compressive strength= 11379 psi.
- Rupture modulus (average 3513 psi) according ASTM C-78
- Water absorption (average 0.136%)
- Non Conductive "dielectric"

## • SPECIFICATIONS

- Polymer concrete cover and frame reinforced with fiberglass
- 3/16" Stainless steel lift pin
- 1/2" Stainless steel hex bolt fastening system
- Load Rating: Tier 22
- Dimensions: 36" x 60" x 48"
- 2 lids
- Tolerances: +- 1.5%
- Aproximate Weight:
  - Cover: 373.5 Lb
  - Box: 745 Lb
- Polymer concrete color: Beige



+1 (844) 238-4371



info@aetherfiber.com | aetherfibersolutions.com